

Optimization of Flexure Bearing Using FEA for Linear Compressor

Gandesri Sai Kiran¹, K.Rajendra Prasad²

¹(Department of Mech Engg, CMR Engineering College, Hyderabad)

²(Assoc. Professor, Department of Mech Engg, CMR Engineering College, Hyderabad)

ABSTRACT: Flexure bearing is a new concept and used for precision applications such as Programmable focusing mechanism (PFM), linear compressor etc. These bearings are compact and inexpensive. A flexure bearing is designed for specific applications. These design can usually be done with the advanced design tool like FEA. With the advent of computers FEA has become the most suitable tool for the engineering analysis where the conventional approach is not suitable, geometric complexity are involved etc. This paper deals with the study of flexure bearings in linear compressor and makes FEA analysis on it to calculate equivalent stress and tries to optimize it. Using software's like CATIA and PROE, modeling of flexure bearing is done. Also make FEM analysis on it by using Ansys software. Gaunekar have made design calculation for flexure bearing to make appropriate model. This bearing contains three spiral slots having 120° apart and 12 peripheral holes are used to clamp the disc rigidly onto a support structure. One central hole made for movement of shaft.

Keywords – Flexure bearing, CATIA model for flexure bearing, Spiral angle, Equivalent stress, FEA analysis.

I. INTRODUCTION

A flexure bearing is a bearing which allows motion by bending a load element. A typical flexure bearing is just one part, joining two other parts. For example, a hinge may be made by attaching a long strip of a flexible element to a door and to the door frame. Another example is a rope swing, where the rope is tied to a tree branch. Design a flexure bearings are a specialized area and requires applications specific approach. Geometrical intricacies, special components, materials and non linearity in behavior of components demand the use of advanced analysis technique. The present work is specific to the typical flexure bearing used in linear compressor. Since the flexural bearing design procedure is not available, this paper proposes to the FEM as a tool to find the equivalent stress that would be offered by a typical flexure used in the linear compressor application. Simple analytical methods are inadequate in predicting the operating characteristics of the flexure bearing due to the mutual coupling effect between the three flexural arms making up the bearing. Use of finite element analysis (FEA) in tackling such a geometrically complicated problem thus becomes indispensable. FEA has been conducted using ANSYS, with a view to examine, apart from the stress distribution characteristics such as equivalent stress, axial stiffness. Dimensions derived from above analytical expressions are to be utilized to develop 3D model of flexural bearing and compressor system. After development of geometric model finite element mesh is to be created and appropriate boundary conditions are to be imposed. Present work can be summarized in analyzing the flexural bearing in following tasks,

Static analysis of flexural bearing to determine axial stiffness, stress distribution etc.

Static analysis to know the effect of spiral angle & slot thickness on stress distribution.

1.1 Applications Of Flexural Bearing :

The Flexural bearing is new concept and there are very precision applications to understand concept of flexural bearing.

1.1.1 Novel Rotary Flexural Bearing:-

A novel rotary flexural bearing is based on the motion principles of elastic flexures. The bearing is capable of providing rotational oscillations of one complete revolution and is characterized by potentially high repeatability, smooth motions, no mechanical wear and no lubrication requirements, no gaps or interfaces, zero maintenance, in addition to its compactness. From the structural characteristics and the basic working principles of the flexural bearings, the study provides a design analysis on the various aspects of the bearing, including material selection, stress analysis and calculations (such as nonlinear finite element analysis, static and fatigue strength designs), motion error analysis and error reduction strategy, parametric design, etc.

Fig.1 shows a schematic view of the rotary flexural bearing which has three bearing sections and is configured as a μ -spindle unit. The bearing consists of inner and outer bearing cages, a bearing shaft, and a μ -coupling that is connected to a μ -servomotor (an external power source). The rotational/oscillational motions of the bearing shaft are guided by the bearing, which is expected to be of extremely high accuracy. The whole design is compact in size without any redundancy. The use of a μ -coupling can minimize the erroneous torque transmission caused by the possible misalignment between the bearing shaft and the servomotor shaft, as well as vibrations and/or error motions of the servomotor. In this way, the rotational/oscillational accuracy of the bearing can be maintained. The bearing is targeted for use in μ -manufacturing and precision metrology, such as μ -EDM, μ -ECM, and ultrasonic μ -machining, laser μ -machining and coordinate measuring machines. The design of the bearing is based on the principle of flexural mechanisms that realizes translational and rotational/oscillational motions of one complete revolution through the elastic deformation of the elastic flexures. The bearing must satisfy the following requirements: It should be able to rotate/oscillate in one complete revolution. It should have sufficient strength and fatigue life for a sustained period of time. It should be compact to fit into the limited spaces in various micro-machines and devices

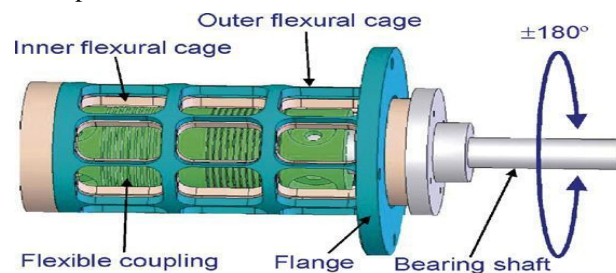

Figure 1 Schematic view of the bearing as a μ -spindle.

1.1.2 Programmable Focussing Mechanism (PFM):

Fig. 2 shows a schematic diagram of the PFM. The moving lens is affixed in a cylindrical tube, which is suspended on two flexure disc assemblies. The space between the flexures is utilized to house a small voice coil motor, which actuates the moving lens and precisely controls its axial position in closed loop servo mode using feedback provided by an LVDT. The position of the fixed lens can be adjusted and locked as and when required for different batches of packages to be bonded. This extends the overall focus range of the optics to the required 3mm, while keeping the stroke requirement of the moving lens to within ± 0.7 mm for any given package, leading to a compact design.

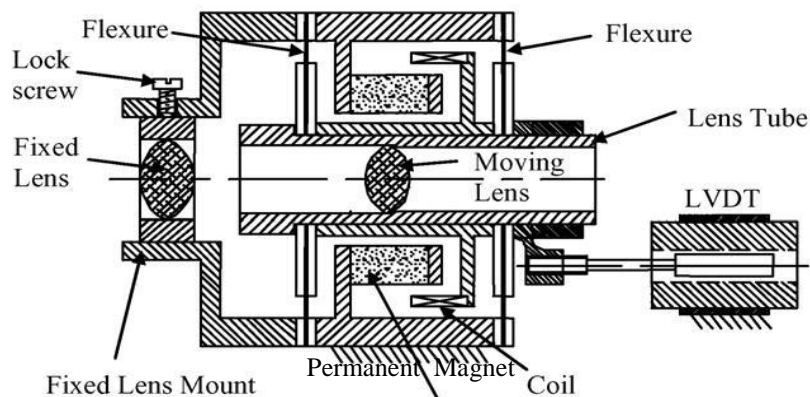

Fig 2. Schematic of programmable focusing mechanism.

Stringent demands on the repeatability of lens position and orientation, call for the use of flexure bearings. Flexures offer incomparably high repeatability of motion since motion is enabled through elastic deformation of the material. Absence of relative motion between two contacting parts leads to frictionless, wear - free operation. Thus, if designed adequately to withstand fatigue, flexure bearings can easily outlast rolling element bearings and slider bearings. They are relatively inexpensive to produce and simple to assemble.

1.1.3 Linear Bearing For Linear Compressor:

The traditional reciprocating-type compressor uses a crankshaft mechanism to convert the rotating motion of an electric motor into reciprocating motion to drive a piston. Cadman and Cohen developed a linear compressor in order to eliminate the common problems of wear, vibration and noise due to the side forces exerted on the piston

and cylinder wall in a reciprocating-type compressor. A linear compressor utilizes a linear motor to directly drive the piston in unidirectional motion. A well-designed linear compressor thus can greatly reduce side forces and wear, as well as vibration and noise.

Fig.3 illustrates the schematic of a linear compressor. Applying an AC current to the coil, which is placed in a magnetic field, the coil/piston component will move back and forth along the axial direction due the electromagnetic effect.

A typical unit of a flexure suspension system used in linear compressor is having each unit is in the form of a thin flat metal disc having three spiral slots, yielding three spiral arms which bear the radial and the axial loads. Stringent demands on the repeatability of lens position and orientation, call for the use of flexure bearings. Flexures offer incomparably high repeatability of motion since motion is enabled through elastic deformation of the material. Absence of relative motion between two contacting parts leads to frictionless, wear - free operation. Thus, if designed adequately to withstand fatigue, flexure bearings can easily outlast rolling element bearings and slider bearings. They are relatively inexpensive to produce and simple to assemble.

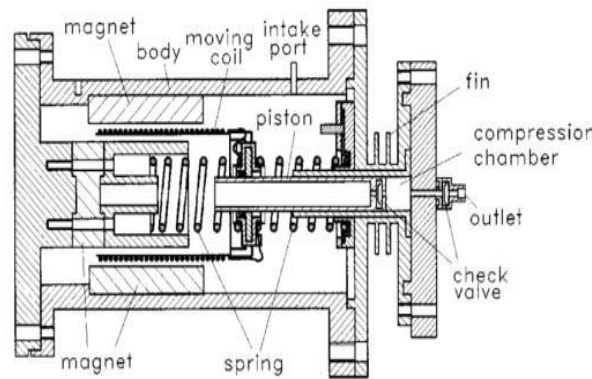

Fig 3. Schematic of Linear Compressor

Previous discussion shows, that typical applications of flexural bearings and its advantages over traditional bearings. It is observed that flexural bearings are best suitable for precision applications. Thus we propose to design and analysis of flexural bearings for these applications as well as it is necessary to carry out simple analytical calculations and complex FEM analysis to predict various parameters of flexural bearings.

1.2 Literature Survey:

Ajit S. Gaunekar, Gary P. Widdowson, Narasimalu Srikanth, Wang Guangneng paper states that Programmable Focusing Mechanism (PFM) is one of the application of flexure bearing in which one is moving lens and one is fixed lens and the position of moving lens is detected by LVDT. The moving lens is affixed in a cylindrical tube which is suspended by two flexure assemblies. The space between two flexures is taken by small voice coil motor which actuates the moving lens. Flexures offer incomparably high repeatability of motion since motion is enabled through elastic deformation of the material [1].

Yingbai XIE, Xiuzhi HUANG, Liangming GUI, Zhouxuan XU paper states that a linear compressor is a piston-type compressor in which the piston is driven by a linear motor, rather than by a rotary motor coupled to a conversion mechanism as in a conventional reciprocating compressor .

Linear motors are simple devices in which axial forces are generated by currents in a magnetic field. Because all the driving forces in a linear compressor act along the line of motion, there is no sideways thrust on the piston, substantially reducing bearing loads and allowing the use of gas bearings or low viscosity oil [2].

H.P. Luo, B. Zhang, Z.X. Zhou paper states that because of the bearing subjected to cyclic stress condition, the fatigue problem must be taken into consideration at the design stage in order to have bearing a long lifetime. Generally titanium or beryllium copper is used as material of bearing[4].

B.J.Huang,Y.C.Chen paper states that traditional reciprocating-type compressor uses a crankshaft mechanism to convert the rotating motion of an electric motor into reciprocating motion to drive a piston. Cadman and Cohen developed a linear compressor in order to eliminate the common problems of wear, vibration and noise due to the side forces exerted on the piston and cylinder wall in a reciprocating-type compressor. A linear compressor utilizes a linear motor to directly drive the piston in unidirectional motion. A well-designed linear compressor thus can greatly reduce side forces , wear, as well as vibration and noise [3].

H.P. Luo, B. Zhang, Z.X. Zhou, paper states an important and challenging research topic has been to design m-machines or m-devices that are capable of micromanipulation, precision motion devices and 3-D m-manufacturing at the nanometric accuracy level. Hence, this study proposes a new concept of bearings i.e. flexural bearings or suspension systems[4].

Ajit S. Gaunekar[1] paper states that for linear compressor in which a typical unit of a flexure suspension system is used. Each unit is in the form of a thin flat metal disc having three spiral slots, yielding three spiral arms which bear the radial and the axial loads. Each spiral sweeps an angle of 480°. In the present work, twelve peripheral holes are used to clamp the disc rigidly onto a support structure. These are slightly oversized with respect to the bolt size to ensure free radial positioning, in order to account for any misalignment between the concerned mating parts. The central hole in the flexure allows for fitting of the shaft snugly. Small holes have been provided at the end of the spiral slots to relieve stress concentration. Sufficient numbers of flexure discs are stacked, together with spacers between consecutive flexures, to obtain the desired axial and radial stiffness. Two such stacks are used for dynamic stability. Unlike the helical spring (low radial stiffness) which has a buckling tendency, the flexure spring has very high radial stiffness compared to the axial stiffness. Generally, Beryllium Copper or Stainless steel is used for manufacturing the flexure bearing.[1]

II. FLEXURE BEARING

A typical unit of a flexure suspension system used in linear compressor is shown in Fig.4. Each unit is in the form of a thin flat metal disc having three spiral slots, yielding three spiral arms which bear the radial and the axial loads. Each spiral sweeps an angle of 480°. The outer diameter of disc is 69 mm and P.C.D. of outer clamped holes is 61 mm. The central hole is having 3 mm diameter while outer clamped 12 holes having diameter 6 mm and thickness of disc is 0.3 mm. The spirals are situated 10 mm apart from centre of disc. The spiral arm is having equal to thickness of 0.5 mm.

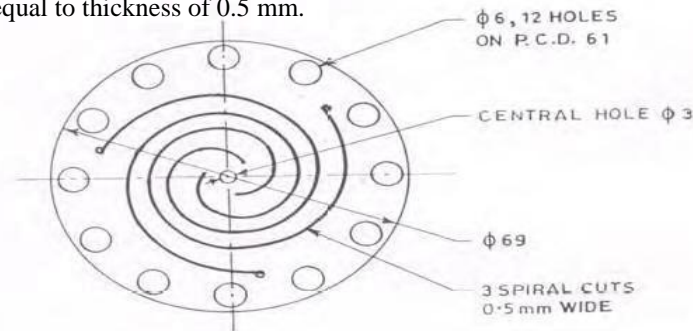

Fig 4 Typical Flexural Unit For Linear Compressor bearing

III. CATIA MODEL OF FLEXURE BEARING

In Catia software, a proper model of flexure bearing with proper dimensions as mentioned above is made.

To create flexure, first go to part design. Then select plane. Click sketcher WB (workbench) icon. By using circle command, draw circle of required diameter that is 69 mm. Then constraint the circle. Also draw twelve holes along the periphery of circle having required diameter equal to 6 mm. Also draw a hole at centre having diameter equal to 3 mm. Exit from WB. Pad circle by 0.15 mm mirror extend i.e. on both side. So, that it will get required thickness of 0.3 mm. For making 12 holes along periphery use pattern command in which give instances and mentioned angle. Similarly, create one hole at centre, use hole command and hole should be positioned and set the option up to next. It will get required hole. The typical task while making model of flexure bearing was to make spiral. These spirals have situated 120 degree apart from each other and 10 mm apart from centre of disc. To make spiral select shape. Then go inside GSD Workbench (Generative Shape Design). Use spiral command from a icon at lower side. Then use translate command to rotate spiral along particular axis (suppose y axis) such that each spiral will be at 120 degree apart from each other. Lastly, by using pocket command, select thick and up to next such that pocket of 0.5 mm create.

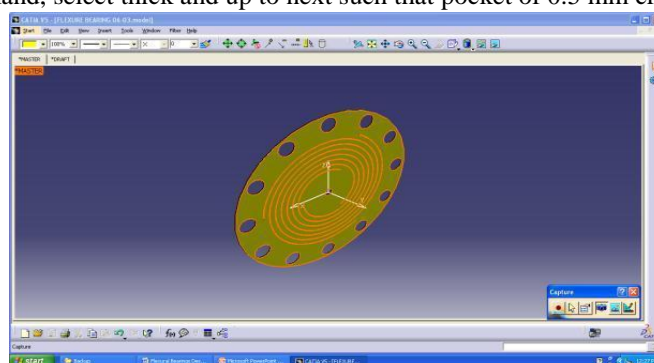

Fig 5. Catia Model For Flexure Bearing

IV. ANALYSIS OF FLEXURE BEARING IN ANSYS

In Ansys v 13 for calculating maximum equivalent stress for axial loading apply force 100 N and solve the results by solver. Following are the results taken from Ansys which are generated by solver for axial loading. The material data used for bearing is given below.

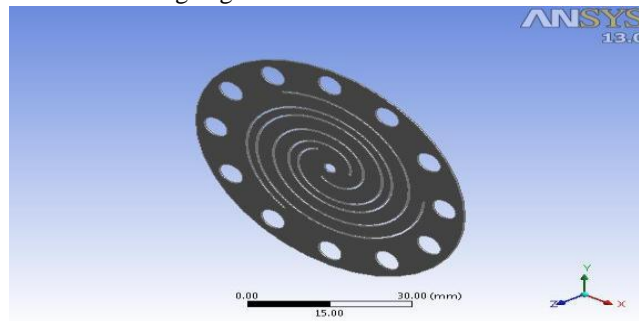

Fig 6. Ansys Model For Flexure Bearing

4.1 Optimization of flexure bearing:

Optimum design of Flexural bearing is done by considering criteria of long fatigue life. The maximum stress is developed at the end of spiral slot. Here main focus is given on the effect of spiral angle as well as spiral slot thickness on maximum stresses for a axial displacement of 5 mm. Here, we have carried out an analysis to know the effect of spiral angle and slot thickness on Stress Distribution & hence on Structural Integrity.

4.1.1 SELECTION OF OPTIMUM SPIRAL ANGLE:

To conduct Structural Analysis and determine the Stress conditions at the end of spiral slot

4.1.2 ANALYSIS INPUTS:

1. Spiral angle varied from 360° to 720° in steps of 120°.
2. Spiral slot thickness is varied from 0.5 mm to 0.65mm in steps of 0.05mm

4.1.3 READINGS TAKEN :

Maximum Stress at the end of spiral slot for a axial displacement of 5mm

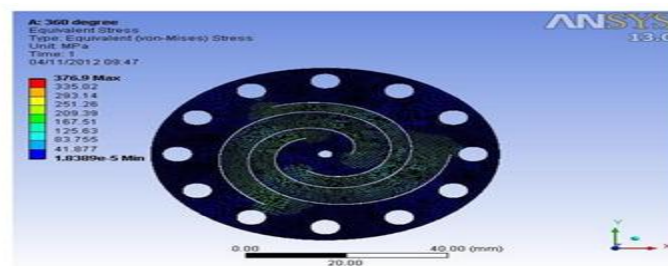

Figure 7 Flexure bearing with 360° spiral

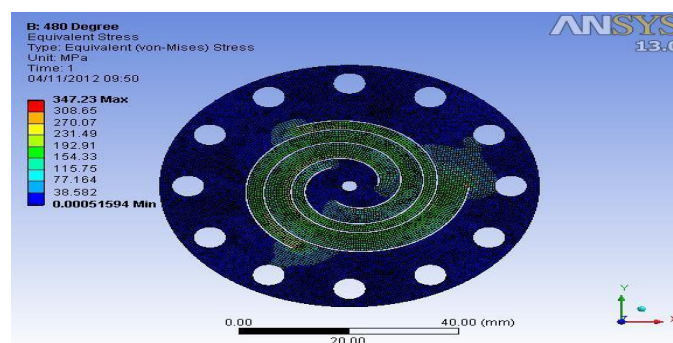

Fig 8. Flexure bearing with 480° spiral

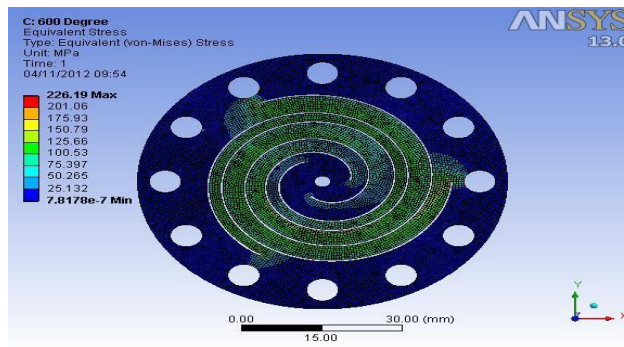

Fig 9. Flexure bearing with 600° spiral

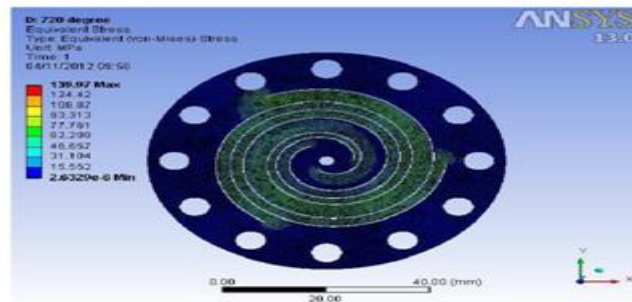

Fig 10. Flexure bearing with 720° spiral

TABLE 1: Observation Table for different spiral Angle

Sr.No.	Displacement,mm	Spiral Angle,°	Equivalent Stress, MPa
1	5	360	376.90
2	5	480	347.23
3	5	600	226.19
4	5	720	139.97

Observation:

From above observation tables we decided to select flexure bearing having 720° spiral angle as it is subjected to less equivalent stress at the end of slot. It also requires less force for 5 mm displacement.

4.1.4 SELECTION OF OPTIMUM SPIRAL SLOT THICKNESS

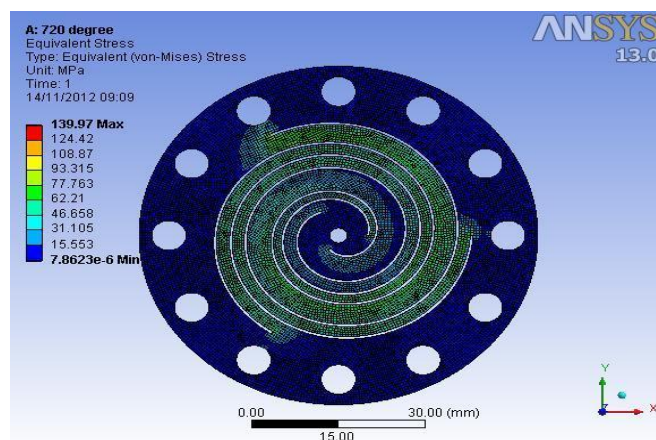

Fig 11. Flexure bearing with 720° spiral and 0.5mm slot thickness

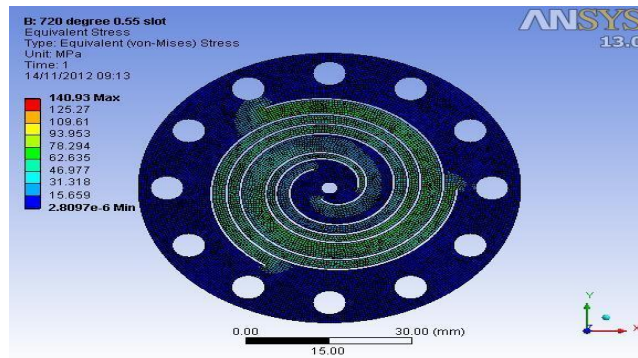

Fig 12. Flexure bearing with 720° spiral and 0.55mm slot thickness

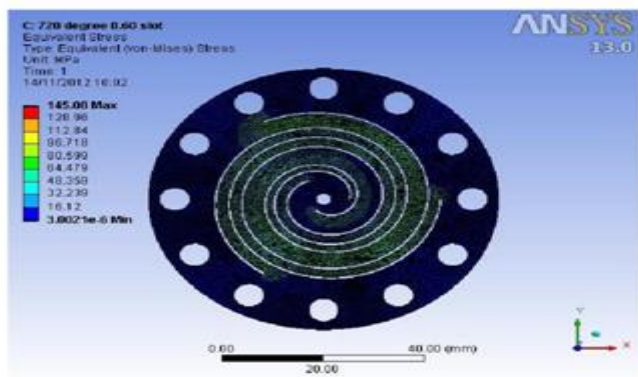

Fig 13. Flexure bearing with 720° spiral and 0.60mm slot thickness

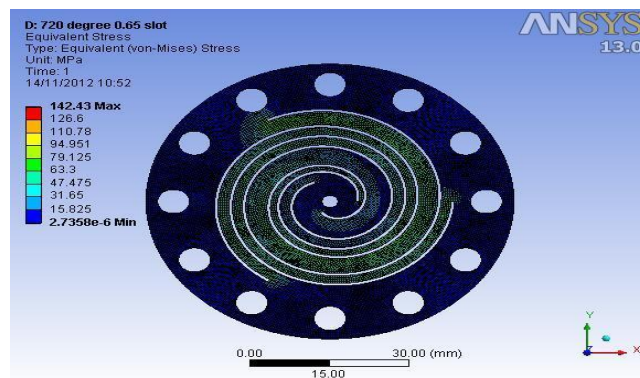

Fig 14. Flexure bearing with 720° spiral and 0.65mm slot thickness

TABLE 2 Observation Table for different slot Thickness

Sr.No.	Displacement,mm	Slot Thickness, mm	Equivalent Stress, MPa
1	5	0.5	139.97
2	5	0.55	140.93
3	5	0.6	145.08
4	5	0.65	142.43

From above observation tables we decided to select flexure bearing having 720° spiral angle and 0.5mm slot thickness as it is subjected to less equivalent stress at the end of slot.

4.2 Material Data:

1) Copper Alloy

Structural properties

Young's Modulus 1.1e+011 Pa

Poisson's Ratio 0.34
Density 8300. kg/m³
Thermal Expansion 1.8e-005 1/°C
Tensile Yield Strength 2.8e+008 Pa
Compressive Yield Strength 2.8e+008 Pa
Tensile Ultimate Strength 4.3e+008 Pa
Compressive Ultimate Strength 0. Pa

Thermal properties

Thermal Conductivity 401. W/m.°C
Specific Heat 385. J/kg.°C
Electromagnetics
Relative Permeability 1.
Resistivity 1.724e-008 Ohm-m

V. CONCLUSION

Flexure bearings are great because they are very simple to manufacture especially compared to some other types of bearings and they are easy and cheap to replace and so maintenance isn't a large issue. Flexure bearings have many advantages including they do not jitter or wobble as they are fixed into place, this minimises the risk of damage to the bearing and the two rigid parts, they can operate in a vacuum, they have virtually an unlimited life span if the atmosphere is not corrosive, they can work in high and low temperatures, and they don't make a noise when they are operating.

- > According to static analysis, we can conclude that flexure bearings with 720° spiral angle develops less equivalent stress (requires lesser amount of force) as compared to bearings with 360° spiral angle.
- > Also, we can conclude that, flexure bearings with 720° spiral angle and 0.5 mm slot thickness. develops less equivalent stress.

5.1. Limitations of Flexure Bearing:

- Range of Motion is Limited.
- Flexure bearing often very limited for bearing that support high loads.

5.2. Applications:

The applications of flexure bearing are extensive and are found in many industries, including

- Automotive
- Medicine
- Machine tools
- Electronics
- Optics
- Pharmaceuticals
- Communications.

The bearing is targeted for use in μ -manufacturing and precision metrology, such as

- μ -EDM
- μ -ECM
- Ultrasonic μ -machining
- Laser μ -machining
- Coordinates measuring machines
- Programmable focusing mechanism

REFERENCES

- [1]. Ajit S. Gaunekar, Gary P. Widdowson, Narasimalu Srikanth, Wang Guangneng, Design and development of a high precision lens focusing mechanism using flexural bearings, Precision Engineering 29, (2005), 81-85
- [2]. Yingbai XIE, Xiuzhi HUANG, Liangming GUI, Zhouxuan XU, Analysis of the No-Load Characteristic of the Moving Coil Linear Compressor, International Compressor Engineering Conference at Purdue, July 14- 17, 2008.
- [3]. B. J. Huang, Y. C. Chen, System Dynamics and Control of a Linear Compressor for Stroke and Frequency Adjustment, Transactions of the ASME, Vol. 124, MARCH 2002,176-182.
- [4]. H.P. Luo, B. Zhang, Z.X. Zhou, A rotary flexural bearing for micromanufacturing, manufacturing Technology 57, (2008), 179- 182.
- [5]. Kyeongbae Park, Eonpyo Hong, Kichul Choi, Wonhyun Jung, Linear Compressor Without Position Controller, International Compressor Engineering Conference at Purdue, July 12-15, 2004.
- [6]. T.R.Chandrupatla, A.D.Belagundu : Finite Elements In Engineering ,Pearsons Education
- [7]. Nitin Gokhale, Sanjay Deshpande : Practical Finite Element Analysis , Finite to Infinite Publications, Pune